

Hup M 28-22 A

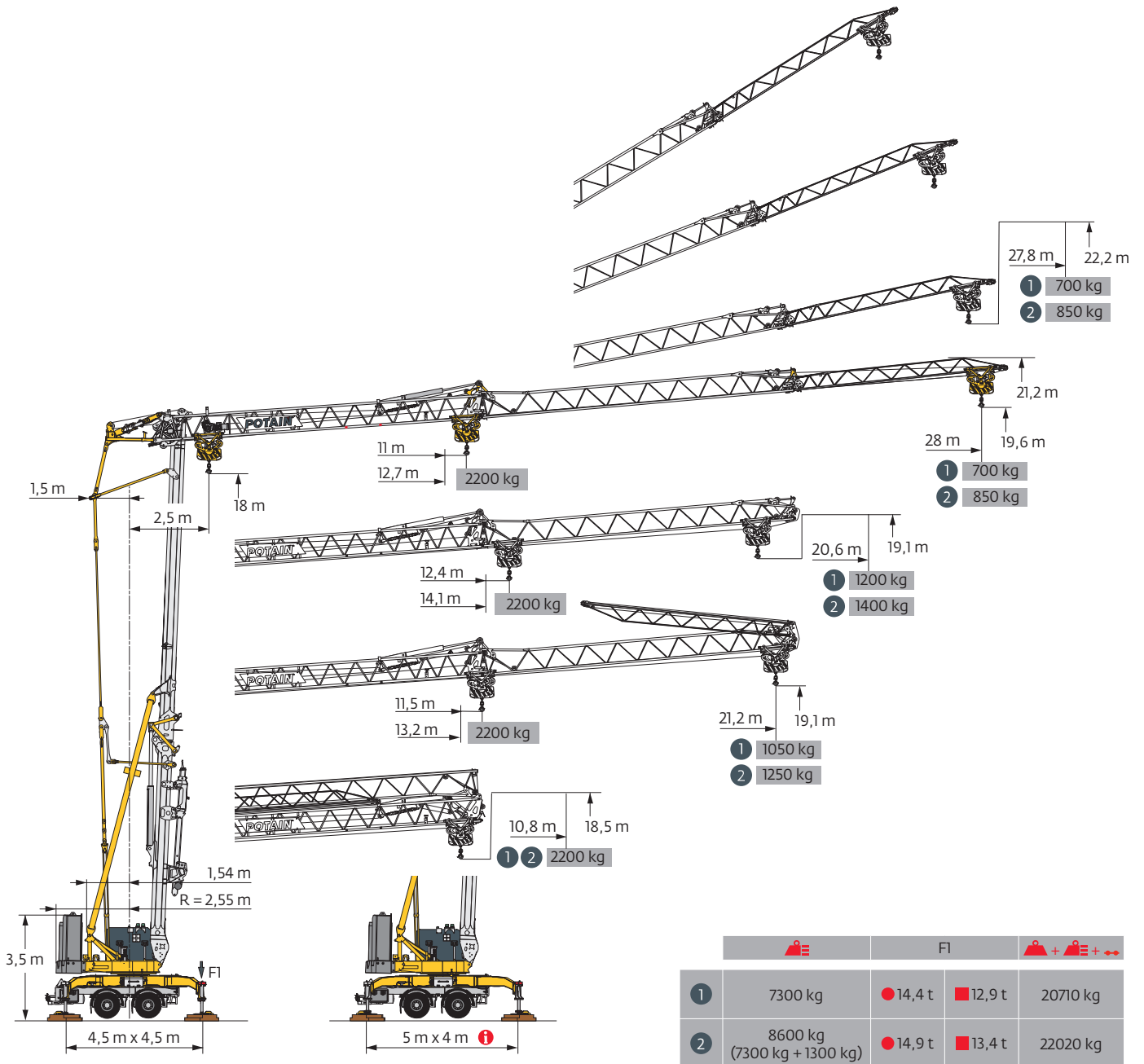

Smart Set-up Drive Control Power Control Steering axle Generator Hydraulic Levelling Top Site

POTAIN CONNECT

Courbes de charges / Lastkurven / Load curves / Curvas de cargas / Curve di carico
 Curvas de carga / Кривые нагрузок

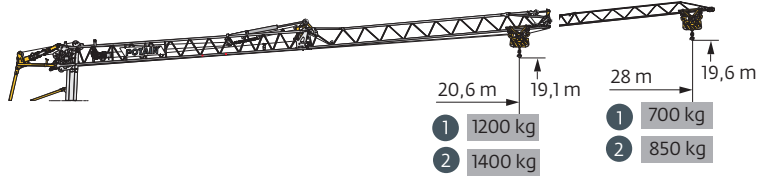
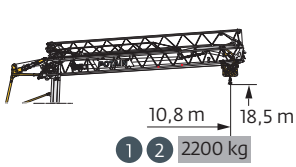

28 m	1	2,5	10,8	2200	2200	2000	1800	1650	1500	1400	1300	1200	1150	1050	950	850	770	700	kg
	2			2200		2200	2150	1950	1800	1650	1550	1450	1350	1300	1150	1050	930	850	kg
20,6 m	1	2,5	10,8	2200															
	2			2200															
	1	2,5	12,4	2200	2100	1900	-	1750	1650	1500	1400	1300	1250	1200					kg
	2							2200	2050	1900	1750	1650	1550	1450	1400				kg



28 m	1	2,5	11,5	2200	2100	1900	-	1750	1500	1300	1150	1050							kg
	2							2200	2050	1750	1500	1350	1250						kg

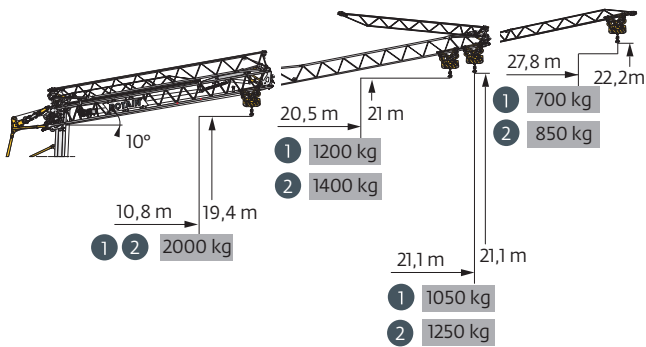

28 m	1	2,5	11,9	2000	1800	-	1500	1300	1200	1000	800	700							kg
	2							2000	1800	1550	1450	1200	970	850					kg





20,6 m	1	2,5	13,4	2000	1750	-	1600	1400	1200										kg
	2							2000	1900	1650	1400								kg

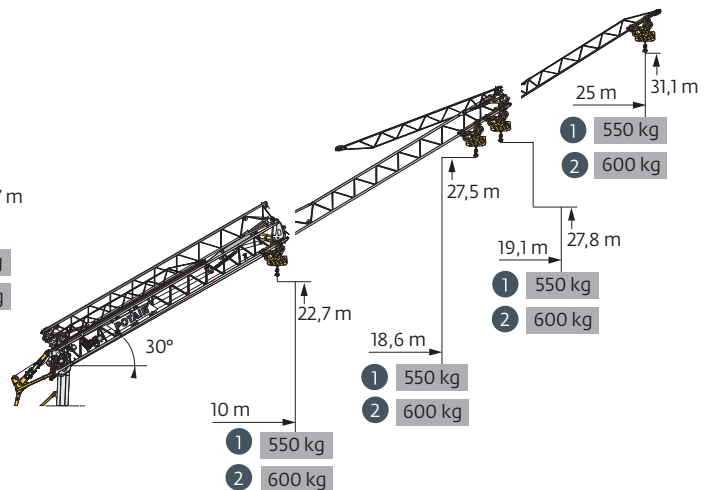
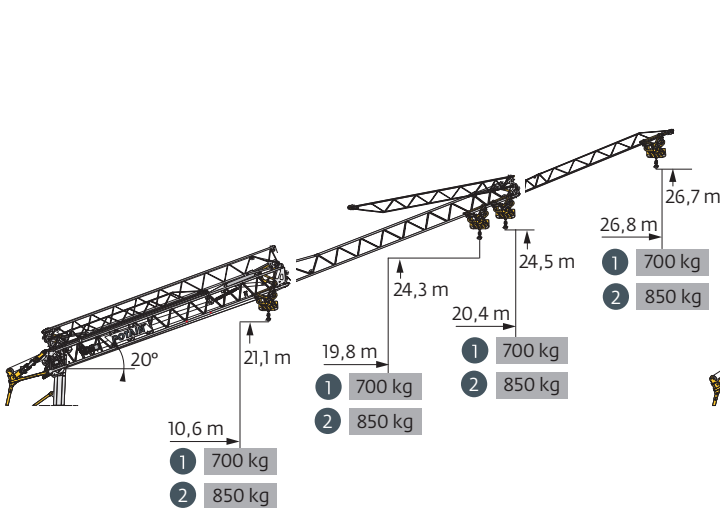

28 m	1	2,5	12,4	2000	1750	-	1600	1450	1250	1050									kg
	2							2000	1900	1750	1500	1250							kg

28-20,6 m	1	2,5	10,8	2000															kg
	2																		kg



Mécanismes / Triebwerke / Mechanisms / Mecanismos / Meccanismi
 Механизмы / Механизмы

230 V - 50 Hz 400 V - 50 Hz 480 V - 60 Hz								ch - PS hp	kW	
	10 LVF 11 Optima	230 V \pm 20 A 1	m/min	1,6	5	10,5	12	17	3,3	2,4
		kg	2200	2200	1000	850	550			
		230 V \pm 32 A 2	m/min	1,6	9	18,5	22	30	5,2	3,8
		kg	2200	2200	1000	850	550			
		400 V / 480 V 3	m/min	1,6	21,5	38,5	42	49	10	7,5
		kg	2200	2200	1000	850	550			
	2 DVF 4 Optima		m/min	1,7	28	35	41	47,5	2	1,5
			kg	2200	2200	1100	600	200		
	HPS 131		tr/min	0 → 0,8					4	3
			U/min rpm							

 IEC 60204-32	 kVA
230 V (+10% -10%) 50 Hz 400 V (+10% -10%) 50 Hz 480 V (+6% -10%) 60Hz	230 V 20 A : 4,6 kVA 230 V 32 A : 7,4 kVA 400 V / 480 V : 11 → 8 kVA 

10 LVF 11 Optima

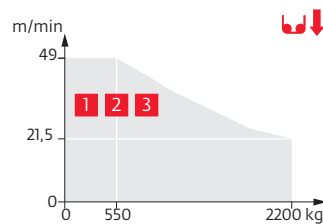
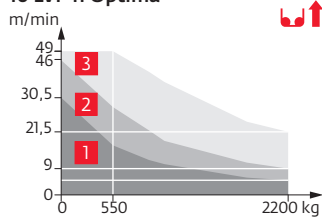

Montage / Montage / Erection / Montaje / Montaggio
 Montagem / Монтаж

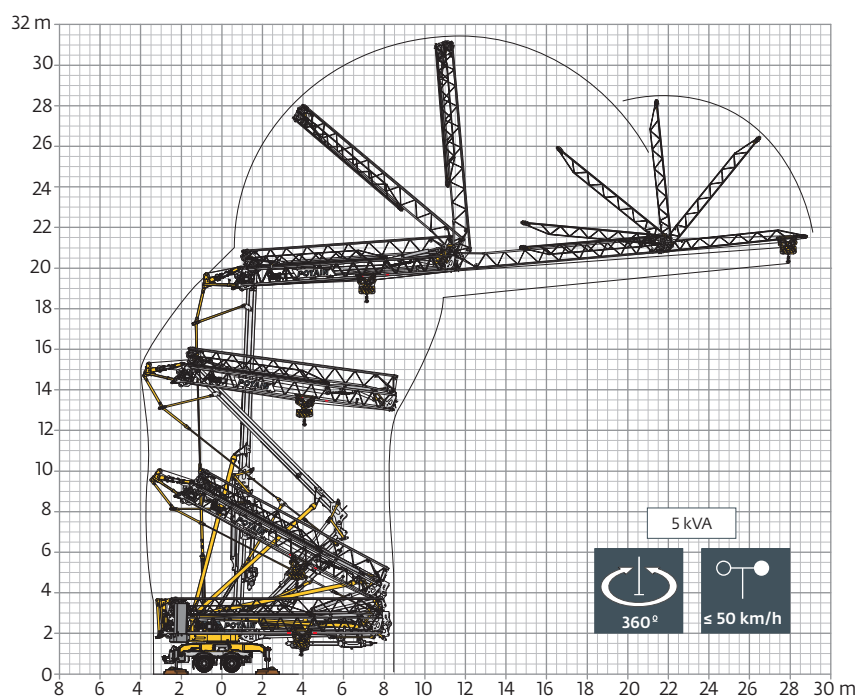

Transport / Transport / Transport / Transporte / Trasporto
Transporte / Транспортировка

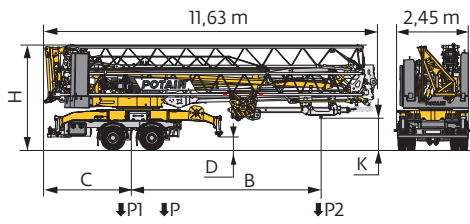

	km/h		B (m)	C (m)	D (m)	H (m)	K (m)	P (kg)	P1 (kg)	P2 (kg)
TSO14/J218D	25		6,53	3,14	0,38/0,48	3,59/3,69	1,12/1,3	20400	19110	1290
	25		8600 kg	6,53	3,14	0,38/0,48	3,59/3,69	1,12/1,3	21710	18810
TSO14/J217D (EBS) ABE / TÜV	80		6,6	3,1	0,45	3,68	1,2/1,28	20760	19350	1410
	80		8600 kg	6,6	3,1	0,45	3,68	1,2/1,28	22060	19050
TSO14/J247D (EBS) RCE / WTA ABE / TÜV	80		6,6	3,1	0,45	3,68	1,2/1,28	21020	19650	1370
	80		8600 kg	6,6	3,1	0,45	3,68	1,2/1,28	22500	19480

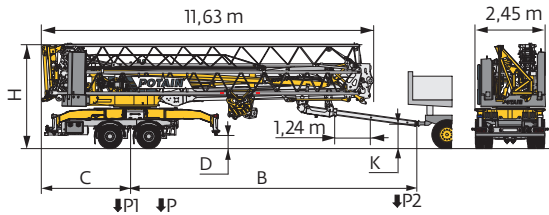

	km/h		B (m)	C (m)	D (m)	H (m)	K (m)	P (kg)	P1 (kg)	P2 (kg)
TSO14/J218D	25		10,21	3,14	0,38/0,48	3,59/3,69	0,67/0,97	20400	19500	900
	80		7300 kg	10,27	3,1	0,45	3,68	0,75/0,95	20760	19800
TSO14/J217D (EBS) ABE / TÜV	80		10,27	3,1	0,45	3,68	0,75/0,95	20760	19800	960
	80		7300 kg	10,27	3,1	0,45	3,68	0,75/0,95	20960	20000
TSO14/J247D (EBS) ABE / TÜV	80		10,27	3,1	0,45	3,68	0,75/0,95	20960	20000	960
	80		7300 kg	10,27	3,1	0,45	3,68	0,75/0,95	20960	20000

	FR	DE	EN	ES	IT	PT	RU
	Rayon de giration	Schwenk radius	Rear slewing radius	Radio de giro	Raggio di rotazione	Raio de rotação	Задний габарит
	Nous consulter	Auf Anfrage	Consult us	Consultarnos	Consultateci	Consultar-nos	Проконсультируйтесь у нас
	Réactions en service	Reaktionskräfte in Betrieb	Reactions in service	Reacciones en servicio	Reazioni in servizio	Reações em serviço	Реакция при работе
	Réactions hors service	Reaktionskräfte außer Betrieb	Reactions out of service	Reacciones fuera de servicio	Reazioni fuori servizio	Reações fora de serviço	Реакция в покое
	Poids à vide, sans lest, sans trains de transport, avec flèche maxi. et hauteur standard.	Gewicht ohne Last, ohne Ballast, ohne Transportachsen mit max. Auslager und Standardhöhe	Weight without load, without ballast, without transport axes, with max. jib and standard height	Peso en vacío, sin lastre, sin trenes de transporte con flecha y altura estandar	Peso a vuoto, senza zavorra, senza assali di trasporto, con braccio max e altezza standard.	Peso em vazio, sem lastro, sem eixos de transporte com lança máxima e altura standard.	Вес без груза, без балласта, без осей для транспортировки, с максимальным вылетом стрелы и стандартной высотой
	Poids total du lest	Ballast-Gesamtgewicht	Total ballast weight	Peso total del lastre	Peso totale della zavorra	Peso total do lastro	Общий вес балласта
	Trains de transport	Transportachsen	Transport axes	Trenes de transporte	Assali di trasporto	Eixos de transporte	Осей для транспортировки
	Équipements standards	Standardausrüstungen	Standard equipment	Equipamiento de serie	Equipaggiamento standard	Equipamento de série	Стандартное оборудование
	Équipements optionnels	Sonderausrüstungen	Options	Equipamiento opcional	Equipaggiamento in opzione	Equipamento opcional	Дополнительное оборудование (опция)
	Levage	Heben	Hoisting	Elevación	Sollevamento	Elevação	Подъем
	Distribution	Katzfahren	Trolleying	Distribución	Distribuzione	Distribuição	Перемещение по стреле
	Orientation	Schwenken	Slewing	Orientación	Rotazione	Rotação	Поворот
	50 Hz Monophasé	50 Hz Einphasige	50 Hz Single phase	50 Hz Monofasica	50 Hz Monofase	50 Hz monofásica	Однофазное напряжение 50Hz
	Puissance requise	Erforderliche Leistung	Required power	Potencia Necesaria	Potenza richiesta	Potência Necessária	Потребляемая мощность
	Transport grue toute lestée.	Krantransport mit voller Ballastierung.	Transport of crane with full ballast.	Transporte grúa completamente lastrada.	Trasporto con gru completamente zavorrata.	Transporte de grua totalmente balastrada.	Перевозка крана с полным балластом
	Fonction Power Control : vitesses treuils adaptées à la puissance disponible	Funktion Power Control: Geschwindigkeiten der Triebwerke werden an die verfügbare Leistung angepasst	Power Control Function: winch speeds adapted to the available power	Función Power Control: marchas de los cabrestantes adaptadas a la potencia disponible	Funzione Power Control: velocità degli organi adattate alla potenza disponibile	Função Power Control: velocidades de guincho adaptadas à potência disponível	Функция контроля мощности Power Control: регулировка скорости лебедок в зависимости от доступной мощности
	Hauteurs sous crochet données moufle plaquée	Hakenhöhen werden mit plattiertem Haken angegeben	Hook heights given with plated pulley block	Altura bajo gancho con pasteca bloqueada	Altezza sotto gancio con bozzello in contatto con carrello	Altura ao gancho com o cadernal em contacto com o carrinho	высота под крюком дана при условии, что крюковая подвеска соприкасается с кареткой
	Document commercial non contractuel	Unverbindliches Vertriebsdokument	This commercial document is not legally binding	Documento comercial no contractual	Documento commerciale non vincolante	Documento comercial não contratual	Этот коммерческий документ не является юридически обязательным
	Pour toute information technique se référer à la notice correspondante	Für technische Informationen, siehe die entsprechenden Anweisungen	For any technical information, please refer to the corresponding instructions	Para cualquier información técnica, ver la noticia correspondiente	Per tutte le informazioni tecniche fare riferimento al catalogo istruzioni	Para qualquer informação técnica complementar consultar as respectivas instruções	Для получения технической информации, см. соответствующие инструкции

