



Mât - Réactions / Mast - Reaktionskräfte / Mast - Reactions / Mástil - Reacciones / Torre - Reazioni  
Tramo - Reações / Реакция опор мачты

**□ 2 m - P 63A - C25**

ΔΔΔΔ (m)	30	35	40	45	50	55	60	65	70	75
↑ (m)	71,6	68,2	69,9	68,2	69,9	68,2	66,6	69,9	66,6	66,6
↑/P↑ (m)	63,2	61,6	61,6	63,2	61,6	63,2	61,6	66,6	66,6	66,6
	3,33 m	0	2	1	2	1	2	0	1	0
	5 m	12	10	11	10	11	10	11	11	11
	10 m	1	1	1	1	1	1	1	1	1
F2 (t)	● 219	212	215	212	218	213	210	218	220	222
	■ 324	298	314	295	318	304	291	331	305	312
F3 (t)	● 155	149	150	146	151	146	143	150	152	154
	■ 269	243	257	238	259	245	232	270	245	252
↑ (m) D25	66,6	66,6	66,6	66,6	64,9	64,9	64,9	64,9	63,2	63,2
↑/P↑ (m) D25	63,2	61,6	61,6	63,2	63,2	64,9	64,9	64,9	63,2	63,2

**□ 2 m - ZX 640 - C25**

ΔΔΔΔ (m)	30	35	40	45	50	55	60	65	70	75
↑ (m)	69,2	67,5	69,2	67,5	67,5	67,5	67,5	67,5	65,9	65,9
↑/P↑ (m)	62,5	62,5	62,5	62,5	62,5	64,2	64,2	65,9	65,9	65,9
	3,33 m	2	0	2	0	0	0	0	1	1
	5 m	10	11	10	11	11	11	11	10	10
	10 m	1	1	1	1	1	1	1	1	1
F1 (t)	● 125	122	124	123	123	123	124	124	126	127
	■ 151	144	153	141	146	147	149	153	149	153
↑ (m) D25	67,5	65,9	65,9	67,5	65,9	65,9	65,9	64,2	64,2	62,5
↑/P↑ (m) D25	62,5	62,5	62,5	62,5	62,5	64,2	64,2	64,2	64,2	62,5

**□ 2,45 m - P 800B - C25**

ΔΔΔΔ (m)	30	35	40	45	50	55	60	65	70	75
↑ (m)	76,6	74,9	74,9	76,6	74,9	74,9	74,9	73,2	71,6	71,6
↑/P↑ (m)	76,6	74,9	74,9	76,6	74,9	74,9	74,9	73,2	71,6	71,6
	3,33 m	0	1	1	0	1	1	2	0	0
	5 m	15	14	14	15	14	14	14	13	14
	10 m	1	1	1	1	1	1	1	1	1
F2 (t)	● 213	210	209	212	209	207	208	211	206	208
	■ 368	359	360	370	363	364	367	361	345	351
F3 (t)	● 139	136	133	134	131	128	129	131	128	129
	■ 303	293	292	300	293	294	297	289	275	280
↑ (m) D25	66,6	66,6	66,6	66,6	66,6	66,6	66,6	64,9	63,2	63,2
↑/P↑ (m) D25	66,6	66,6	66,6	66,6	66,6	66,6	66,6	64,9	63,2	63,2

**□ 2 m - V 60A - C25**

ΔΔΔΔ (m)	30	35	40	45	50	55	60	65	70	75
↑ (m)	65,9	65,9	65,9	65,9	65,9	65,9	65,9	62,5	62,5	62,5
↑/P↑ (m)	60,9	59,2	60,9	60,9	60,9	62,5	60,9	62,5	62,5	62,5
	3,33 m	0	0	0	0	0	0	2	2	2
	5 m	12	12	12	12	12	12	10	10	10
	10 m	1	1	1	1	1	1	1	1	1
F1 (t)	● 116	117	116	113	117	117	117	116	116	117
	■ 139	140	140	137	142	142	145	130	135	140
↑ (m) D25	57,5	57,5	57,5	59,2	57,5	57,5	57,5	57,5	55,9	55,9
↑/P↑ (m) D25	57,5	57,5	57,5	59,2	57,5	57,5	57,5	57,5	55,9	55,9

**□ 2,45 m - P 854A - C25**

ΔΔΔΔ (m)	30	35	40	45	50	55	60	65	70	75
↑ (m)	89,9	89,9	89,9	89,9	89,9	89,9	88,2	88,2	88,2	86,6
↑/P↑ (m)	89,9	89,9	89,9	89,9	89,9	89,9	88,2	88,2	88,2	86,6
	3,33 m	1	1	1	1	1	2	2	2	0
	5 m	17	17	17	17	17	17	16	16	16
	10 m	1	1	1	1	1	1	1	1	1
F2 (t)	● 258	260	258	257	258	256	252	261	263	258
	■ 542	546	546	544	550	552	532	539	547	524
F3 (t)	● 175	174	172	169	170	167	165	172	173	170
	■ 466	469	468	464	470	471	453	458	465	444
↑ (m) D25	79,9	79,9	79,9	79,9	79,9	79,9	78,2	78,2	76,6	76,6
↑/P↑ (m) D25	79,9	79,9	79,9	79,9	79,9	79,9	78,2	78,2	76,6	76,6

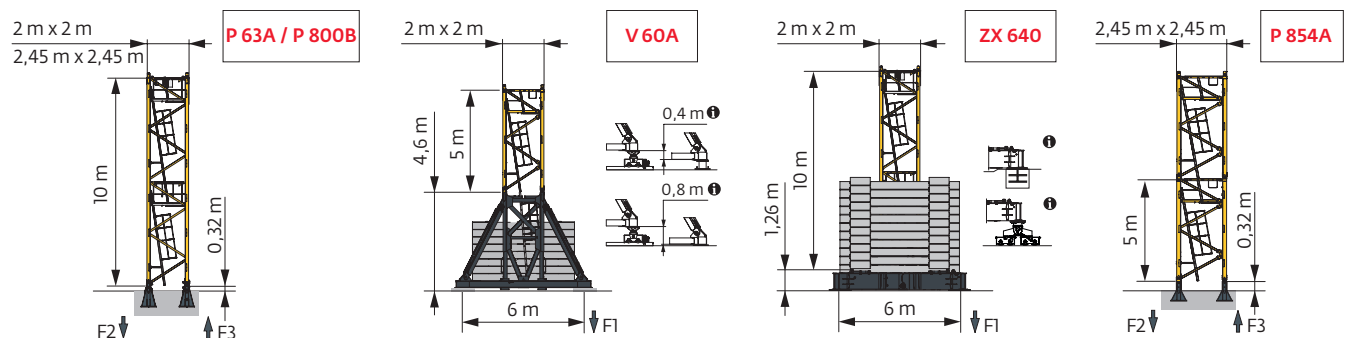

**2,45 m - JM 850 - C25**

Δ (m)	30	35	40	45	50	55	60	65	70	75
h (m)	94	94	94	94	94	94	92,3	92,3	90,7	90,7
h/P+ (m)	94	94	94	94	94	94	92,3	92,3	90,7	90,7
3,33 m	1	1	1	1	1	1	2	2	0	0
5 m	16	16	16	16	16	16	15	15	16	16
Fl (t)	● 149	150	150	147	150	150	146	149	144	147
	■ 233	234	234	233	235	236	230	233	224	227

h (m) D25	84	82,3	82,3	84	82,3	82,3	82,3	82,3	82,3	80,7
h/P+ (m) D25	84	82,3	82,3	84	82,3	82,3	82,3	82,3	82,3	80,7

**2,45 m - ZY 800 - C25**

Δ (m)	30	35	40	45	50	55	60	65	70	75
h (m)	74,6	74,6	74,6	74,6	72,9	72,9	72,9	72,9	72,9	71,3
h/P+ (m)	74,6	74,6	74,6	74,6	72,9	72,9	72,9	72,9	72,9	71,3
3,33 m	2	2	2	2	0	0	0	0	0	1
5 m	13	13	13	13	14	14	14	14	14	13
Fl (t)	● 130	131	131	128	123	123	123	129	129	128
	■ 179	181	181	179	169	170	172	177	182	178

h (m) D25	64,6	64,6	64,6	64,6	64,6	64,6	64,6	62,9	62,9	62,9
h/P+ (m) D25	64,6	64,6	64,6	64,6	64,6	64,6	64,6	62,9	62,9	62,9

**2,45 m - ZX 6830 - C25**

Δ (m)	30	35	40	45	50	55	60	65	70	75
h (m)	65,8	65,8	65,8	67,5	65,8	65,8	65,8	64,2	62,5	62,5
h/P+ (m)	65,8	65,8	65,8	67,5	65,8	65,8	65,8	64,2	62,5	62,5
3,33 m	1	1	1	0	1	1	1	2	0	0
5 m	12	12	12	13	12	12	12	11	12	12
Fl (t)	● 130	131	131	135	131	131	131	132	125	126
	■ 167	169	169	174	170	171	173	170	157	162

h (m) D25	57,5	57,5	57,5	57,5	57,5	57,5	57,5	55,8	55,8	54,2
h/P+ (m) D25	57,5	57,5	57,5	57,5	57,5	57,5	57,5	55,8	55,8	54,2

**2,45 m - ZY 854 - C25**

Δ (m)	30	35	40	45	50	55	60	65	70	75
h (m)	86,5	86,5	86,5	86,5	86,5	86,5	86,5	84,9	84,9	83,2
h/P+ (m)	86,5	86,5	86,5	86,5	86,5	86,5	86,5	84,9	84,9	83,2
3,33 m	1	1	1	1	1	1	1	2	2	0
5 m	16	16	16	16	16	16	16	15	15	16
Fl (t)	● 167	168	169	170	170	170	170	172	172	167
	■ 257	260	261	260	264	266	268	263	269	256

h (m) D25	73,2	73,2	73,2	74,9	74,9	74,9	73,2	73,2	73,2	73,2
h/P+ (m) D25	73,2	73,2	73,2	74,9	74,9	74,9	73,2	73,2	73,2	73,2

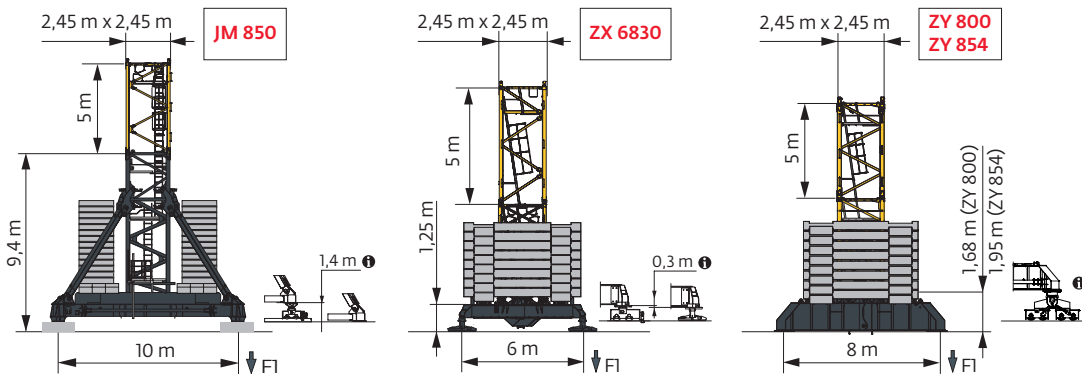

**i** Autres compositions de pylône - Nous consulter. / Andere Turmaufbauten - bitte kontaktieren Sie uns. / Other mast compositions - Please consult us. / Para otras composiciones de mástil - Por favor contáctenos. / Per altre composizioni torre, contattateci. / Para outras composições de coluna - Por favor, consulte-nos. / Для других композиций мачты пожалуйста проконсультируйтесь с нами.

Accès motorisés : compositions de mâture, de lest de base et réactions adaptées. / Motorisierter Zugang vom : Mastzusammensetzung, Grundballast und Reaktionskräfte sind angepasst. / Motorized accesses: adapted mast composition, base ballast and reactions. / Acceso a cabina con elevador: Adaptación de composición de mástil, lastre de base y reacciones. / Accessi motorizzati: composizioni elementi torre, zavorre di base e reazioni aggiornate. / Acessos motorizados: composições de coluna, lastro da base e reações adaptadas. / Лифты : адаптированная композиция мачты, базовый балласт и нагрузки.

Ancrages / Verankerungen / Anchorages / Anclajes / Ancoraggi  
Ancoragem / нкера

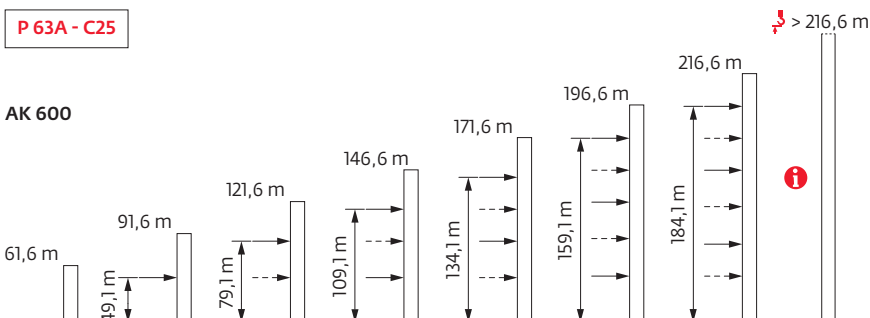

Lest de base / Grundballast / Base ballast / Lastre de base / Zavorra di base  
 Lastro da base / Базовый Балласт

**⚖️ (t) / 📏 2 m - V 60A - 🚛 - C25**

▲▼▲ (m)	30	35	40	45	50	55	60	65	70	75
65,9	120	120	120	108	120	120	120			
62,5	108	108	108	108	96	96	96	108	108	108
57,5	96	96	96	96	96	84	84	96	96	96
52,5	96	96	96	84	84	84	84	84	72	72
47,5	96	96	84	84	84	72	72	60	60	60
42,5	84	84	84	72	72	72	60	60	48	60
37,5	84	84	84	72	72	72	60	48	48	48
32,5	84	84	84	72	72	72	60	48	48	48

**⚖️ (t) / 📏 2 m - ZX 640 - 🚛 - C25**

▲▼▲ (m)	30	35	40	45	50	55	60	65	70	75
69,2	140		130							
67,5	130	130	130	130	130	130	130	130		
65,9	120	120	120	120	120	120	120	120	130	130
60,9	110	110	110	110	110	100	100	100	110	110
55,9	100	100	100	100	90	90	90	80	90	90
50,9	100	100	100	90	90	90	90	80	80	70
45,9	90	90	90	80	80	70	70	70	60	60
40,9	80	80	80	80	70	70	60	60	50	50
35,9	80	80	70	70	70	70	60	50	40	50

**⚖️ (t) / 📏 2,45 m - JM 850 - 🚛 - C25**

▲▼▲ (m)	30	35	40	45	50	55	60	65	70	75
94	192	192	192	180	192	192				
92,3	180	180	180	180	180	180	180			
90,7	168	168	168	156	168	168	168	168	168	180
85,7	132	132	132	120	132	132	132	132	132	144
80,7	108	108	96	96	96	96	96	96	108	108
75,7	72	72	72	72	72	72	72	72	72	84
70,7	48	48	48	48	48	48	48	48	48	60
65,7 ↓	48	48	48	48	48	48	48	48	48	48
35,7	48	48	48	48	48	48	48	48	48	48

**⚖️ (t) / 📏 2,45 m - ZX 6830 - 🚛 - C25**

▲▼▲ (m)	30	35	40	45	50	55	60	65	70	75
67,5				161						
65,8	151	151	151	141	151	151	151			
64,2	141	141	141	131	141	141	141	151		
62,5	121	121	121	111	111	111	121	121	131	131
57,5	101	91	91	91	91	91	81	91	91	101
52,5	81	81	81	71	71	71	71	81	81	71
47,5	81	81	81	71	71	71	61	61	61	61
42,5	81	81	81	71	71	71	61	51	41	51
37,5	81	81	81	71	71	71	61	51	41	51

**⚖️ (t) / 📏 2,45 m - ZY 800 - 🚛 - C25**

▲▼▲ (m)	30	35	40	45	50	55	60	65	70	75
74,6	132	132	132	120						
72,9	120	120	108	108	108	108	108	120	120	
71,3	108	108	108	96	96	96	108	108	108	120
66,3	72	72	72	60	72	72	72	72	84	84
61,3	48	48	48	36	36	36	36	48	48	48
56,3	36	36	36	36	24	24	24	36	24	24
51,3	36	24	24	24	24	12	12	24	12	12
46,3 ↓	24	24	24	24	24	12	12	12	12	12
31,3	24	24	24	24	24	12	12	12	12	12

**⚖️ (t) / 📏 2,45 m - ZY 854 - 🚛 - C25**

▲▼▲ (m)	30	35	40	45	50	55	60	65	70	75
86,5	216	216	216	216	216	216	216			
84,9	204	204	204	204	204	204	216	216	216	
83,2	192	192	192	180	180	192	192	192	204	204
78,2	156	156	144	144	144	144	156	156	156	168
73,2	120	120	108	108	108	108	108	120	120	132
68,2	84	84	84	72	84	84	84	84	84	96
63,2	48	48	48	48	48	48	48	48	60	60
58,2	36	24	24	24	24	24	24	24	24	36
53,2	24	24	24	12	12	12	12	12	12	12
48,2 ↓	12	12	12	12	12	12	12	12	12	12
33,2	12	12	12	12	12	12	12	12	12	12

Courbes de charges / Lastkurven / Load curves / Curvas de cargas / Curve di carico / Curvas de carga / Кривые нагрузок



↕ (m)		17	20	25	27	30	32	35	37	40	42	45	47	50	55	57	60	65	67	70	72	75	m	
↕	↕ 16 t	↕											↕											
↕	↕ ↔ ↕ 8 t	↕											↕											
75	3,3 → 18,6	34,1-37,3	16	14,9	11,6	10,6	9,4	8,7	8	8	7,4	7	6,5	6,1	5,6	4,9	4,7	4,4	3,9	3,7	3,5	3,3	3,1	t
	3,3 → 20,5	36-39,1	16	16	12,8	11,7	10,3	9,4	8,3	8	7,7	7,3	6,7	6,3	5,8	5,2	4,9	4,6	4,1	4	3,7	3,6	3,3	t P+
70	3,3 → 19,7	35,9-39,1	16	15,7	12,3	11,3	10	9,3	8,3	8	7,7	7,2	6,6	6,2	5,7	5	4,8	4,5	4	3,9	3,7		t	
	3,3 → 21,1	36,4-39,7	16	16	13,2	12	10,5	9,6	8,5	8	7,8	7,4	6,8	6,4	5,9	5,3	5	4,7	4,2	4	3,8		t P+	
65	3,3 → 21,1	38,8-42	16	16	13,3	12,2	10,8	10	9	8,5	8	8	7,4	7	6,5	5,7	5,4	5,1	4,6				t	
	3,3 → 22,5	39,4-42,6	16	16	14,1	12,8	11,3	10,4	9,3	8,7	8	8	7,5	7,1	6,6	5,9	5,6	5,3	4,8				t P+	
60	3,3 → 22,4	40,4-43,5	16	16	14,1	12,9	11,4	10,6	9,5	8,9	8,1	8	7,7	7,3	6,8	6,1	5,8	5,5					t	
	3,3 → 24	42-45,2	16	16	15,2	13,9	12,2	11,3	10,1	9,4	8,5	8	8	7,6	7,1	6,3	6	5,7					t P+	
55	3,3 → 22,7	41,8-45,1	16	16	14,4	13,2	11,8	10,9	9,9	9,2	8,4	8	8	7,6	7,1	6,4								t
	3,3 → 24,4	44,4-48	16	16	15,5	14,3	12,7	11,8	10,6	9,9	9,1	8,6	8	8	7,6	6,9								t P+
50	3,3 → 22,7	41,9-45,2	16	16	14,4	13,2	11,8	10,9	9,9	9,3	8,5	8	8	7,7	7,1									t
	3,3 → 24,8	45,4-49	16	16	15,9	14,6	13	12	10,9	10,2	9,3	8,8	8,1	8	7,8									t P+
45	3,3 → 23,7	43,7-45	16	16	15,1	13,9	12,4	11,5	10,4	9,7	8,9	8,4	8											t
	3,3 → 25,9		16	16	16	15,3	13,6	12,7	11,4	10,7	9,8	9,2	8,5											t P+
40	3,3 → 23,5		16	16	14,9	13,6	12,1	11,2	10,1	9,4	8,6													t
	3,3 → 25,5		16	16	16	15	13,3	12,3	11,1	10,4	9,5													t P+
35	3,3 → 23,7		16	16	15	13,8	12,2	11,3	10,2															t
	3,3 → 25,8		16	16	16	15,2	13,4	12,4	11,2															t P+
30	3,3 → 23,8		16	16	15,1	13,9	12,3																	t
	3,3 → 25,8		16	16	16	15,3	13,5																	t P+

$W_{jib} = W_{counter-jib} - 0,88 \text{ t max.}$



↕ (m)		17	20	25	27	30	32	35	37	40	42	45	47	50	55	57	60	65	67	70	72	75	m	
↕	↕ 16 t	↕											↕											
↕	↕ ↔ ↕ 8 t	↕											↕											
75	2,5 → 18,8	34,6-35,6	16	15	11,7	10,8	9,5	8,8	8	7,6	7	6,6	6	5,6	5,2	4,5	4,2	3,9	3,4	3,3	3	2,85	2,65	t
	2,5 → 20,6	36,5-37,2	16	16	12,9	11,8	10,5	9,6	8,4	8	7,3	6,8	6,2	5,9	5,4	4,7	4,5	4,1	3,7	3,5	3,2	3,1	2,85	t P+
70	2,5 → 19,8	36,4-37,2	16	15,8	12,5	11,4	10,1	9,4	8,4	8	7,3	6,8	6,1	5,8	5,3	4,6	4,3	4	3,6	3,4	3,2			t
	2,5 → 21,3	36,9-38	16	16	13,3	12,2	10,6	9,7	8,6	8	7,4	6,9	6,3	6	5,5	4,8	4,6	4,2	3,7	3,6	3,4			t P+
65	2,5 → 21,3	39,4-40,2	16	16	13,4	12,3	11	10,2	9,2	8,6	8	7,6	7	6,6	6,1	5,3	5	4,7	4,2					t
	2,5 → 22,6	39,9-40,8	16	16	14,2	13	11,4	10,5	9,4	8,8	8	7,7	7,1	6,7	6,2	5,5	5,2	4,9	4,4					t P+
60	2,5 → 22,6	41-42	16	16	14,3	13,1	11,6	10,7	9,7	9	8,2	8	7,3	7	6,5	5,7	5,5	5,2						t
	2,5 → 24,2	42,6-43,5	16	16	15,4	14	12,4	11,4	10,2	9,6	8,7	8,1	7,7	7,3	6,7	5,9	5,7	5,3						t P+
55	2,5 → 22,9	42,5-43,4	16	16	14,5	13,4	11,9	11,1	10	9,4	8,6	8,1	7,7	7,3	6,8	6,1								t
	2,5 → 24,5	45,1-46,1	16	16	15,7	14,4	12,8	11,9	10,7	10,1	9,2	8,7	8	7,8	7,3	6,5								t P+
50	2,5 → 22,9	42,5-43,5	16	16	14,6	13,4	11,9	11,1	10	9,4	8,6	8,1	7,7	7,3	6,8									t
	2,5 → 25	46,1-46	16	16	16	14,7	13,1	12,2	11	10,3	9,5	8,9	8,2	7,9	7,5									t P+
45	2,5 → 23,9	44,4-45	16	16	15,3	14	12,5	11,6	10,5	9,9	9	8,5	8											t
	2,5 → 26,1		16	16	16	15,4	13,7	12,8	11,6	10,9	9,9	9,4	8,7											t P+
40	2,5 → 23,7		16	16	15	13,8	12,2	11,3	10,2	9,6	8,7													t
	2,5 → 25,7		16	16	16	15,1	13,4	12,4	11,2	10,5	9,6													t P+
35	2,5 → 23,9		16	16	15,2	13,9	12,3	11,4	10,3															t
	2,5 → 26		16	16	16	15,3	13,6	12,6	11,3															t P+
30	2,5 → 24		16	16	15,3	14	12,4																	t
	2,5 → 26		16	16	16	15,4	13,6																	t P+



$W_{jib} = W_{counter-jib} - 0,27 \text{ t max.}$

Poids de flèche & lest de contre-flèche / Auslegergewicht & Gegenauslegerballast / Jib weight & counter-jib ballast / Peso de flecha y lastre de contra-flecha/Peso del braccio & zavorra di contro-braccio/Peso da lança & lastro da contra lança/Вес стрелы и балласт контр-стрелы

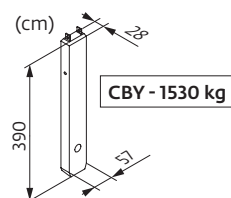
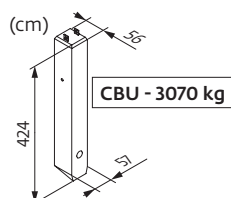
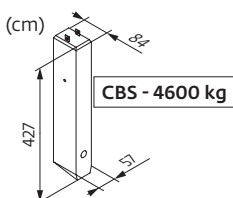

↕	↕ (kg) (+/- 5%)			↕		↕		↕	
	↕ ↔ ↕	↕	↕ ↔ ↕	4600 kg	1530 kg	↕ (kg)	3070 kg	1530 kg	↕ (kg)
75 m	18300	17805	18450	5	2	26060	8	1	26090
70 m	18035	17555	18175	5	2	26060	8	1	26090
65 m	17650	17200	17820	5	2	26060	8	1	26090
60 m	16725	16305	16875	5	1	24530	8	0	24560
55 m	16735	16315	16885	5	1	24530	8	0	24560
50 m	15920	15500	16070	5	2	26060	8	1	26090
45 m	15660	15240	15810	5	2	26060	8	1	26090
40 m	14845	14425	14995	5	0	23000	7	1	23020
35 m	14315	13895	14465	4	2	21460	7	0	21490
30 m	13475	13055	13625	4	1	19930	6	1	19950







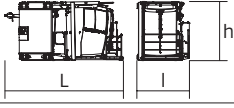
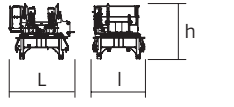
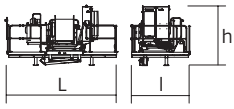

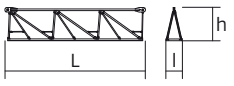
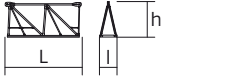
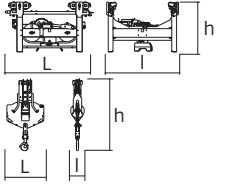
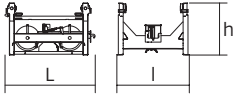
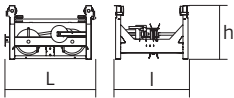
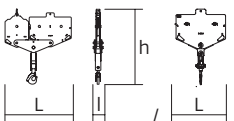
Encombremet et poids / Abmessungen und Gewicht / Dimensions and weight / Dimensiones y peso / Ingombro e peso  
 dimensões e pesos / габаритные размеры и вес

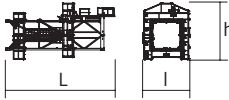

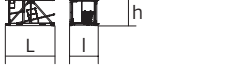
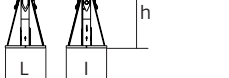
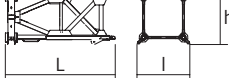

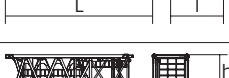
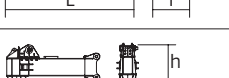
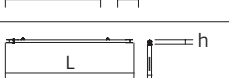
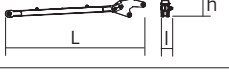
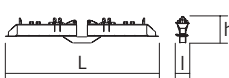
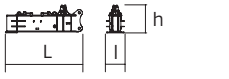



Partie tournante / Drehender Kranteil / Slewing crane part / Parte giratoria  
 Parte rotante / Parte rotativa / Поворотная часть :  75 m -  75 HPL™

























Partie tournante / Drehender Kranteil / Slewing crane part Parte giratoria / Parte rotante / Parte rotativa / Поворотная часть		L (m)	l (m)	h (m)	kg (+/- 5%)
Contre-flèche / Gegenausleger Counter-jib / Contra-flecha Controbraccio / Contra-lança Контр-стрела		12 12 12	1,25 1,25 1,25	2,5 2,5 2,5	14110 13600 11540
Mât-cabine + cabine / Kabinenmast + Kabine Cab mast + cab / Mástil-cabina + cabina Portaralla superiore + cabina / Tramo-cabina + cabina Секция мачты кабины + кабина		5,03	2,22	2,49	6720
Pivot / Krankopf Towerhead / Pivote Portaralla / Pivot Секция поворотной части		2,95 3,25	2,48 2,5	2,5 2,75	7620 8700
Treuil de levage (+ câble) / Hubwerk (+ Seil) Hoisting winch (+ rope) / Mecanismo de elevación (+ cabo) Argano di sollevamento (+ fune) Guincho de elevação (+ cabo) Подъемная лебедка (+ канатом)		4,27 4,86	2,3 2,28	2,32 2,52	4090 6870
Élément de flèche / Auslegerement Jib section / Elemento de flecha Elemento di braccio / Elemento de lança Секция стрелы		10,75	1,8	2,74	5450
Élément de flèche / Auslegerement Jib section / Elemento de flecha Elemento di braccio / Elemento de lança Секция стрелы		10,21 10,31 10,22 10,24 10,19	1,2 1,2 1,2 1,2 1,2	2,5 2,42 2,39 2,1 1,83	3145 2420 1560 1235 950
Élément de flèche / Auslegerement Jib section / Elemento de flecha Elemento di braccio / Elemento de lança Секция стрелы		5,27 5,09 5,09	1,2 1,2 1,2	2,39 1,53 1,39	960 310 220
Chariot + Moufle / Laufkatze + Hubflasche Trolley + Pulley block/ Carrello + Aparejo Carro + Bozzello/ Carro-distribuidor + Cadernal Тележка + Полиспаст		2,05	1,51	1,09	482
Chariot / Laufkatze Trolley / Carrello Carro / Carro-distribuidor Тележка		1,77	1,53	1,05	250
Chariot / Laufkatze Trolley / Carrello Carro / Carro-distribuidor тележка		1,77	1,53	1,05	303
Moufle / Hubflasche Pulley block / Aparejo Bozzello / Cadernal Полиспаст		1,83 1,16	0,28 0,22	1,9 1,6	845 370

Pyłõne / Kranturm / Crane tower Mástil / Torre / Torre / Башня крана		L (m)	l (m)	h (m)	kg (+/- 5%)	
T 61 T 851		2 m 2,45 m	10,83 11,18	4,14 4,84	4,47 5,8	9700 15750
K 649B KM 649E KRM 6410B KRM 849B K 85/KR 84B2 KM 850.10B KM 850.14B		2 m 2 m 2 m 2,45 m 2,45 m 2,45 m 2,45 m	10,23 10,29 10,23 10,24 10,24 10,32 10,32	2,07 2,03 2,1 2,55 2,54 2,54 2,54	2,03 2,03 2,08 2,53 2,5 2,51 2,51	5290 4850 7100 7800 9635 10070 11190
K 649A KMT 649A KR 649A KRMT 649A K 849A KMT 849A KR 849A KRMT 849A K 85/KR 84A2 KMT 850.10A KMT 850.14A		2 m 2 m 2 m 2 m 2,45 m 2,45 m 2,45 m 2,45 m 2,45 m 2,45 m 2,45 m	5,23 5,23 5,23 5,23 5,23 5,23 5,23 5,23 5,24 5,32 5,32	2,07 2,07 2,1 2,1 2,53 2,55 2,53 2,55 2,54 2,54 2,54	2,03 2,03 2,08 2,08 2,5 2,53 2,5 2,53 2,5 2,51 2,51	2805 2570 3250 3050 3400 3150 4290 4090 5550 5450 5990
K 649C KMT 649C KRMT 649C KRMT 849C		2 m 2 m 2 m 2,45 m	3,57 3,57 3,57 3,57	2,07 2,07 2,1 2,55	2,03 2,03 2,08 2,53	2070 2060 2450 3205
Pieds de scellement / VerankerungsfüÙe Fixing angles / Pie de empotramiento Montante da annegare / Angulos fixadores анкера		P 63A / P 800B P 854A	0,75 0,9	0,75 0,9	1,28 1,5	465 940
Mât-châssis / Grundmasteinheit Basic mast unit / Tramo-chasis Elemento base / Tramo-chassis Мачта для крепления к шасси		V 60A	5,01	2,41	2,41	4760
Haubans / Mastabstütungen / Struts / Tornapuntas Puntoni / Escoras / Растяжка		V 60A	4,51	0,29	0,29	470
Sommier / Unterwagenhälfte Half-bearer / Testero Testata / Estrutura base Траверса		V 60A	6,7	0,7	2,31	1840
Croix centrale (position transport) / Zentralkreuz (Transport- position) / Central cross (transport position) / Brazo central (posición transporte) / Croce centrale (posizione di trasporto) Braço central chassis (posição transporte) / крестообразное основание (транспортное положение)		JM 850	5,2	1,7	1,5	6700
Mât-châssis / Grundmasteinheit Basic mast unit / Tramo-chasis Elemento base / Tramo-chassis Мачта для крепления к шасси		JM 850	8,75	2,5	2,5	14600
Bras de châssis / Unterwagenträger / Chassis girder / Brazo de base en cruz / Traverso del carro / Braço de chassis / опорная балка шасси		JM 850	5,2	0,9	1,55	3200
Tirant de châssis / Unterwagenstreben / Chassis ties / Tirante de base en cruz / Tiranti del carro / Tirante de chassis / тяга крепления шасси		JM 850	7,2	0,25	0,35	250
Haubans / Mastabstütungen / Struts / Tornapuntas Puntoni / Escoras / Растяжка		JM 850	8,2	0,75	1,3	2300
Bras de croix / Fundamentkreuzträger Cross girder / Brazo en cruz / Braccio croce / Braço da cruz Поперечная балка		ZX 6830	9,1 9,1	1,12 0,76	1,1 1,48	5265 5445
1/2 Bras de croix / 1/2 Fundamentkreuzträger 1/2 Cross girder / 1/2 Brazo en cruz 1/2 Braccio croce / 1/2 Braço da cruz 1/2 Поперечная балка		ZX 640 ZY 800 ZY 854	4,35 5,68 5,7	1 0,98 0,98	1,56 1,92 2,27	3320 4720 6430
Bras de croix / Fundamentkreuzträger Cross girder / Brazo en cruz / Braccio croce / Braço da cruz Поперечная балка		ZX 640 ZY 800 ZY 854	9,15 11,96 11,9	1,19 1,39 1,42	1,56 1,92 2,27	6880 10075 14000

Mécanismes / Triebwerke / Mechanisms / Mecanismos / Meccanismi  
 Механизмы / Механизмы

400 V - 50 Hz													ch - PS hp	kW	
	<b>75 HPL™ 40</b>	m/min	33,5	44	63	110	167	17,5	23	33	57,5	83,5	75	55	539 m
		t	8	6	4	2	0,5	16	12	8	4	1,4			
	<b>110 HPL™ 40</b>	m/min	50,5	65,5	92	134	194	26	34	48	68,5	102,5	110	82	1140 m
		t	8	6	4	2	0,2	16	12	8	4	0,4			
	<b>6 DVF 6 Optima</b>	m/min	0 → 42 (16 t) 0 → 84 (8 t) 0 → 100 (4 t)									5,5	4		
	<b>RVF 172 Optima+</b>	tr/min U/min rpm	0 → 0,8									2 x 10	2 x 7,5		
															

 IEC 60204-32		
400 V (+10% -10%) 50 Hz	75 HPL™ : 84 → 54 kVA 110 HPL™ : 112 → 68 kVA	

	<b>FR</b>	<b>DE</b>	<b>EN</b>	<b>ES</b>	<b>IT</b>	<b>PT</b>	<b>RU</b>
	Profil de vent suivant EN 14439 C25-D25	Windbedingungen gemäss EN 14439 C25-D25	Wind conditions according to EN 14439 C25-D25	Conformidad de los condiciones de viento EN 14439 C25-D25	Condizioni del vento secondo EN 14439 C25-D25	Perfil de vento conforme EN 14439 C25-D25	Ветровой режим в соответствии с EN 14439 C25-D25
	Appel de flèche	Auslegerüberhöhung	Jib elevation	Elevación de la flecha	Inclinazione braccio	Desvio da lança	подъем стрелы
	Équipements standards	Standardausrüstungen	Standard equipment	Equipamiento de serie	Equipaggiamento standard	Equipamento de série	Стандартное оборудование
	Équipements optionnels	Sonderausrüstungen	Options	Equipamiento opcional	Equipaggiamento in opzione	Equipamento opcional	Дополнительное оборудование (опция)
	Fonction Potain Plus : Courbes de charges Plus	Funktion Potain Plus: Plus-Lastkurven	Potain Plus function: Plus load curves	Función Potain Plus: Diagrama de cargas Plus	Funzione Potain Plus: Curve di carico Plus	Função Potain Plus: Diagrama de cargas Plus	Функция контроля мощности Potain Plus: Диаграммы грузоподъемности Plus
	Hauteurs sous crochet associées aux courbes de charges Plus	Hakenhöhen mit Plus-Lastkurven	Hook heights with Plus load curves	Altura bajo gancho, usando el diagrama de cargas Plus	Altezze sotto gancio con curve di carico Plus	Altura livre, utilizando o diagrama de cargas Plus	Высота под крюком для диаграмм грузоподъемности Plus
	Réactions en service	Reaktionskräfte in Betrieb	Reactions in service	Reacciones en servicio	Reazioni in servizio	Reações em serviço	Реакция при работе
	Réactions hors service	Reaktionskräfte außer Betrieb	Reactions out of service	Reacciones fuera de servicio	Reazioni fuori servizio	Reações fora de serviço	Реакция в покое
	Poids total du lest	Ballast-Gesamtgewicht	Total ballast weight	Peso total del lastre	Peso totale della zavorra	Peso total do lastro	Общий вес балласта
	Cadre d'ancrage serré	Fester Verankerungsrahmen	Tightened anchorage frame	Marco de anclaje de apriete	Quadro di ancoraggio stretto	Quadro de amarração apertado	Прикрепленная анкерная рама
	Cadre d'ancrage desserré	Looser Verankerungsrahmen	Loosened anchorage frame	Marco de anclaje de desapriete	Quadro di ancoraggio allentato	Quadro de amarração solto	Отсоединенная анкерная рама
	Poids de flèche	Auslegergewicht	Jib weight	Peso de flecha	Peso del braccio	Peso da lança	вес стрелы
	Camion 13,4 m	Lkw 13,4 m	Lorry 13,4 m	Camión 13,4 m	Camion 13,4 m	Camião 13,4 m	Ррузовой автомобиль 13,4 м
	Conteneur High Cube 40', et/ou Flat Rack 20'	Container High Cube 40', und/oder Flat Rack 20'	Container High Cube 40', and/or Flat Rack 20'	Contenedor High Cube 40', y/o Flat Rack 20'	Container High Cube 40', e/ou Flat Rack 20'	Contentor High Cube 40', e/ou Flat Rack 20'	40-футовый контейнер повышенной вместимости High Cube, и/или 20-футовая открытая платформа Flat Rack
	Levage	Heben	Hoisting	Elevación	Sollevamento	Elevação	Подъем
	Distribution	Katzfahren	Trolleying	Distribución	Ditribuzione	Distribuição	Перемещение по стреле
	Orientation	Schwenken	Slewing	Orientación	Rotazione	Rotação	Поворот
	Translation	Kranfahren	Travelling	Traslación	Traslazione	Translação	Перемещение крана
	Puissance requise	Erforderliche Leistung	Required power	Potencia Necesaria	Potenza richiesta	Potência Necessária	Потребляемая мощность
	Fonction Power Control : vitesses treuils adaptées à la puissance disponible	Funktion Power Control: Geschwindigkeiten der Triebwerke werden an die verfügbare Leistung angepasst	Power Control Function: winch speeds adapted to the available power	Función Power Control: marchas de los cabrestantes adaptadas a la potencia disponible	Funzione Power Control: velocità degli argani adattate alla potenza disponibile	Função Power Control: velocidades de guincho adaptadas à potência disponível	Функция контроля мощности Power Control: регулировка скорости лебедок в зависимости от доступной мощности
	Nous consulter	Auf Anfrage	Consult us	Consultarnos	Consultateci	Consultar-nos	Проконсультируйтесь у нас
	Document commercial non contractuel. Pour toute information technique se référer à la notice correspondante.	Unverbindliches Vertriebsdokument. Für technische Informationen, siehe die entsprechenden Anweisungen.	This commercial document is not legally binding. For any technical information, please refer to the corresponding instructions.	Documento comercial no contractual. Para cualquier información técnica, ver la noticia correspondiente.	Documento commerciale non vincolante, per tutte le informazioni tecniche fare riferimento al catalogo istruzioni.	Documento comercial não contractual. Para qualquer informação técnica complementar consultar as respectivas instruções.	Этот коммерческий документ не является юридически обязательным. Для получения технической информации, см. соответствующие инструкции.

